



UNILIFT SERIES · UNI-P

Traction Hoist Range

REF.: UNI70A-9P11-S · UNI70A-9P11-T · UNI100A-9P11-T

The UNILIFT is an electric traction hoist for temporarily and permanent-installed suspended access platforms and elevator cars. Lifting is produced by friction between an authorised steel wire rope and the internal traction sheave, using an α -shaped rope-winding mechanism.

The rope passes through the hoist at constant speed and is not stored inside the machine, so the lifting height depends only on the length of rope available. Every unit is factory-tested and supplied with an integrated OSLA overspeed secondary brake.



UNILIFT Traction Hoist



01 MODEL LINEUP

UNI70A-9P11-S	UNI70A-9P11-T	UNI100A-9P11-T
208 V · 1-PHASE	208 V · 3-PHASE	208 V · 3-PHASE
1,500 lbs 680 kg WLL	1,500 lbs 680 kg WLL	2,200 lbs 1,000 kg WLL
Power: 2 hp Rated current: 12 A Control box: 1P	Power: 3 hp Rated current: 9 A Control box: 3P	Power: 3 hp Rated current: 9 A Control box: 3P

02 PERFORMANCE & ELECTRICAL DATA

PARAMETER	UNI70A-9P11-S	UNI70A-9P11-T	UNI100A-9P11-T
Ultimate working load	1,500 lbs / 680 kg	1,500 lbs / 680 kg	2,200 lbs / 1,000 kg
Lifting speed	35 fpm / 10.7 m/min	35 fpm / 10.7 m/min	35 fpm / 10.7 m/min
Wire-rope diameter	3/8" / 9.5 mm	3/8" / 9.5 mm	3/8" / 9.5 mm
Supply voltage / frequency	208 V / 60 Hz	208 V / 60 Hz	208 V / 60 Hz
Phases	1P	3P	3P
Motor power	2 hp / 1.5 kW	3 hp / 2.2 kW	3 hp / 2.2 kW
Rated current	12 A	9 A	9 A
Net weight	159 lbs / 72 kg	159 lbs / 72 kg	159 lbs / 72 kg
Power connector	3-pin / 3-core	4-pin / 4-core	4-pin / 4-core

*Accessories



03 GENERAL CHARACTERISTICS

Drive principle	Friction traction
Lifting height	Unlimited (rope length)
Primary brake	Electromagnetic
Secondary brake	OSLA overspeed lock
Sound power	≤ 79 dB @ 3.3 ft
Protection class	IP55

Gearbox	Double reduction
Overload protection	Trips at 125% WLL
Motor protection	Thermal + overcurrent
Phase protection	Seq./loss/voltage
Manual lift	Handwheel (optional)
Emergency descent	Speed-limited

Operating environment. -4 °F to +131 °F (-20 °C to +55 °C); humidity ≤ 90 % at 77 °F; supply tolerance ± 5 %; gust ≤ grade 5 (27.23 ft/s). Non-corrosive, non-explosive, fully-lit sites only.

04 SAFETY

- Use only FAS-Technology authorised 3/8" (9.5 mm) steel wire rope, in good condition.
- Installation, operation, inspection, maintenance and electrical work by qualified, authorised personnel only.
- Do not overload, modify, dismantle or repair the hoist without FAS-Technology authorisation.
- The hoist may not be operated without a functioning OSLA secondary brake; the OSLA cannot be used on its own.
- Do not use in potentially explosive atmospheres, or with a damaged or non-authorised wire rope.
- Keep the load in view, never stand beneath it, and fit an anti-falling device when carrying persons.
- Electrical connection must comply with applicable regulations and include suitable protection (RCD ≤ 30 mA).

05 COMPLIANCE

UL 1323

CSA Z271

EN 1808:2015

EN 60204-1

Scaffold hoists · Suspended platforms · Suspended access equipment · Electrical equipment of machines

06 DIMENSIONS

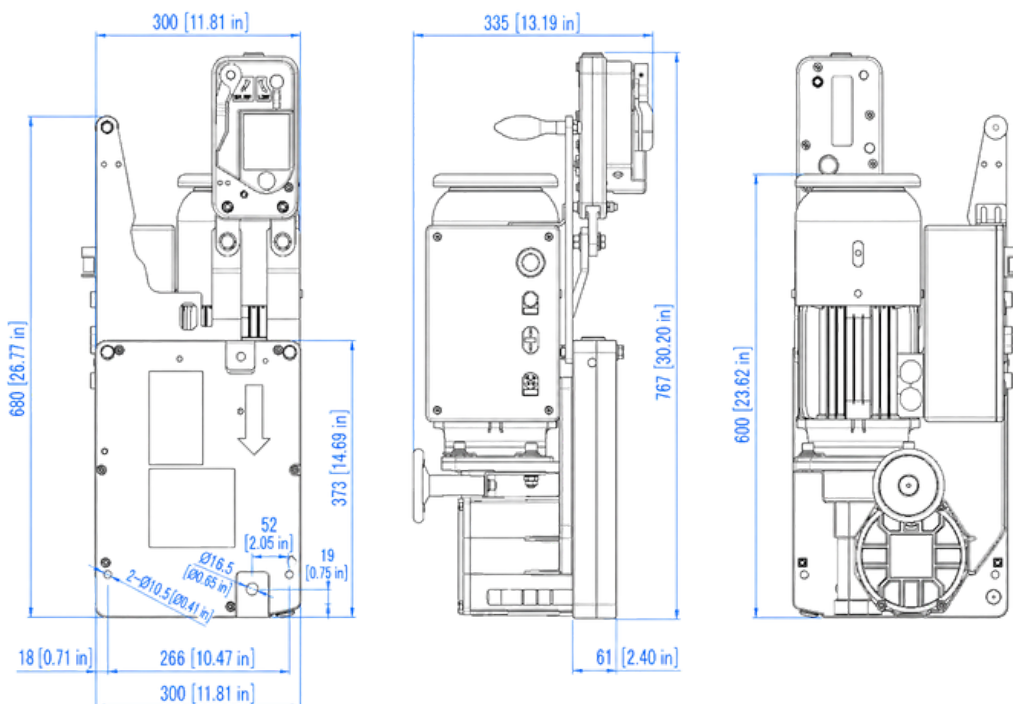

Overall width	11.8 in (300 mm)
Overall height	30.2 in (767 mm)
Mounting holes	1 × Ø0.65 in
Fixing	5/8" pin / M16-8.8
Orientations	Front/lateral/inverted
Flat install.	Not permitted

Nominal; refer to the drawing and to FAS-Technology for installation-specific values.



07 OSLA SECONDARY BRAKE

Every UNILIFT is supplied with an integrated OSLA (overspeed safety lock) secondary brake, mounted above the rope inlet and shipped together with the hoist on two connecting plates.

The OSLA automatically locks the wire rope on rope breakage or overspeed descent. It must always remain fitted — the hoist cannot be operated without it, and the OSLA cannot be used on its own.



OSLA overspeed safety lock

Model	OSLA	Type	Independent mech.
Rope diameter	3/8" (9.5 mm)	Working load limit	2,200 lbs (1,000 kg)
Locking speed	98 ft/min	Locking distance	≤ 10.2 in
Reset	Manual only	Overhaul cycle	500 h @ 98 ft/min

08 WIRE ROPE

Construction	5×K19S-SFC, fibre core	Lay	Right-hand
Diameter	3/8" (9.5 mm)	Tensile strength	313 ksi (2,160 MPa)
Min. breaking force	16,200 lbf (72.1 kN)	Reel length range	328 - 1,312 ft
End termination	Crimped alu sleeve	Approval	FAS authorised only

09 ELECTRICAL CONNECTION

Main switch	Required
Residual current device	RCD/ELCB ≤ 30 mA
Overcurrent protection	Type C fuse
Generator sizing	≥ 3 × rated power
Connector — 1P/3P	3-pin / 4-pin

Supply cable	164 ft 50 m	328 ft 100 m	656 ft 200 m
Cable (AWG)	16	14	12
All models — by working height.			

Electrical connection must comply with applicable national standards; supply voltage and frequency must match the hoist nameplate. The on-site supply must include a leakage-protection switch.

10 LUBRICATION & SERVICE

Gear oil	MOBIL SHC 632 synth.	Oil capacity	1.6 qt (1.5 L) · inv. 2.1 qt
Oil temp. range	-22 to +140 °F	Brake clearance	0.012-0.016 in
Service interval	100 h / per site / annual	Overhaul cycle	500 working hours

Use original FAS-Technology spare parts only. Annual safety inspection and overhaul by FAS-Technology or an authorised workshop.